

Dimensions are in millimeters

| Shell size | PART NUMBER | B   | C    | D     | E     | F     | G    | H    | I     | J     | K     | ØN   |
|------------|-------------|-----|------|-------|-------|-------|------|------|-------|-------|-------|------|
| E          | 8630.16     | 2.4 | 2.4  | 24.99 | 30.55 | 20.21 | 12.3 | 12.7 | 12.28 | 10.74 | 18.6  | 8    |
| A          | 8630.17     | 2.4 | 3.2  | 33.32 | 38.89 | 28.55 | 12.3 | 12.7 | 12.28 | 10.74 | 27    | 10   |
| B          | 8630.18     | 3.2 | 4.75 | 47.04 | 52.78 | 42.29 | 12.3 | 12.7 | 12.28 | 10.74 | 40.5  | 15   |
| C          | 8630.19     | 3.2 | 6.35 | 63.50 | 69.06 | 58.75 | 12.3 | 12.7 | 12.28 | 10.74 | 56.96 | 18   |
| D          | 8630.20     | 3.2 | 4.75 | 61.11 | 66.67 | 56.36 | 12.3 | 15.4 | 15.15 | 13.02 | 55.03 | 20.6 |

NOTES

- MATERIAL : STEEL
- PLATING : YELLOW CHROMATE CADMIUM
- CORROSION RESISTANCE : 50 HOURS EXPOSURE TO SALT SPRAY
- PACKAGING : PER 100 PIECES

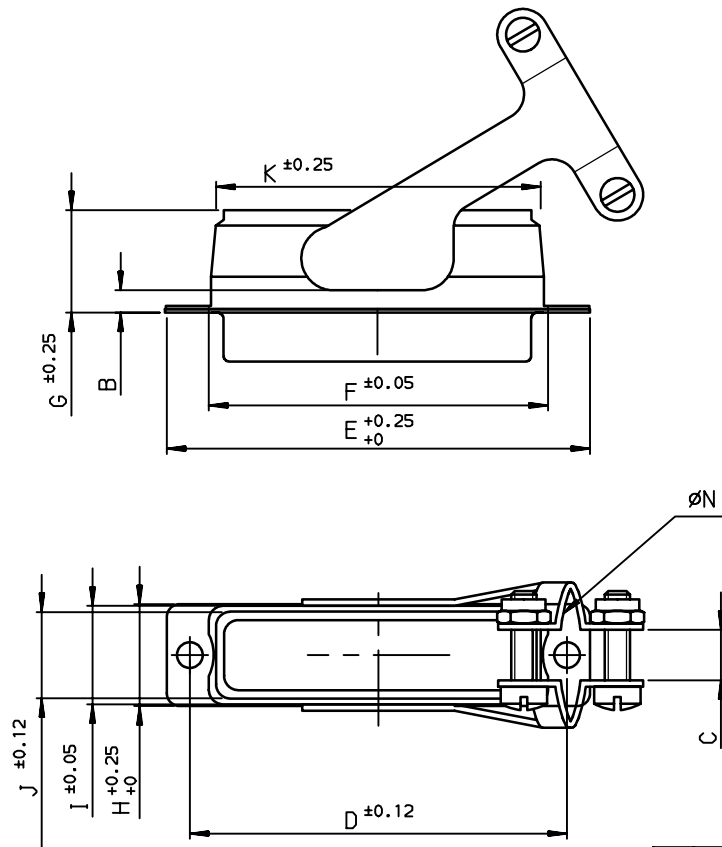

European Views

|                                       |         |                     |  |                                    |                |                  |
|---------------------------------------|---------|---------------------|--|------------------------------------|----------------|------------------|
| www.fciconnect.com                    |         | surface<br>ISO 1302 | <input checked="" type="checkbox"/>                    | tolerance std<br>ISO 406 ISO 1101  | projection<br> | mm               |
| TOLERANCES UNLESS OTHERWISE SPECIFIED |         |                     |  | 0.X                                | ±0.1           | size<br>A3       |
| Dr                                    | JOUBERT | 2002/04/11          | ANGULAR  | 0.XX                               | ±0.1           | Scale<br>1.5     |
| Eng                                   | PESSON  | 2002/04/11          | LINEAR   | 0.XXX                              | ±0.1           | ECN<br>LS06-0097 |
| Chr                                   | LEGARE  | 2002/04/11          | 0.XX' ±2'  | Product family<br>D-SUB Spec ref - |                |                  |
| Appr                                  | LEGARE  | 2002/04/11          | Title<br>METAL HOOD WITH CIRCULAR CLAMP AND ANGLE EXIT |                                    |                |                  |
| catalog no                            |         | -                   |  | dwg no<br>C01-8655-1559            |                | Rev.<br>B        |
| CUSTOMER                              |         | sheet 1 of 1        |  |                                    |                |                  |

| rev | ecn no    | dr  | date       |
|-----|-----------|-----|------------|
| A   | -         | JOU | 2002/04/11 |
| B   | LS06-0097 | LGO | 2006/07/28 |
| -   | -         | -   | -          |
| -   | -         | -   | -          |
| -   | -         | -   | -          |
| -   | -         | -   | -          |